

**KU LEUVEN**

# Exploring a Modular Approach to Signal Processing Systems: From Gravitational Wave Analysis to Hearing Systems

Arwen Mannaert

[arwen.mannaert@kuleuven.be](mailto:arwen.mannaert@kuleuven.be)

Faculty of Engineering Science, Department of Electrical Engineering, KU Leuven

AISED Conference: <https://www.dtrsociety.org/aised2025/>

November 18, 2025



University  
of Antwerp



Digital Transformation  
RESEARCH SOCIETY

# About me

- **Education**

- BSc Engineering Science**

- Major: Electrical Engineering, Minor: Mechanical Engineering*

- KU Leuven, Leuven, Belgium*

**2020-2023**

- MSc Electrical Engineering**

- Option - Information Systems and Signal Processing*

- KU Leuven, Leuven, Belgium*

**2023-2025**

- **Work Experience**

- NSX - Niel, Belgium**

- Software developer, industrial PhD student*

**2025-**



Arwen Mannaert

# Overview

*Exploring a Modular Approach to Signal Processing Systems: From Gravitational Wave Analysis to Hearing Systems*

- A modular approach to Gravitational Wave Analysis
- A modular approach to integrating Hearing Instrument functionalities
- Applications to other fields
- Infusing AI

# Gravitational Wave Analysis

**A Modular Wavelet Analysis Pipeline for the Detection of Gravitational Waves with the Einstein Telescope**



# Gravitational Wave Research Context

- 2015: First detection of gravitational waves
- Fast-paced research
- New Generation detectors:
  - LISA
  - Einstein Telescope
- cWB data analysis pipeline

## Einstein Telescope

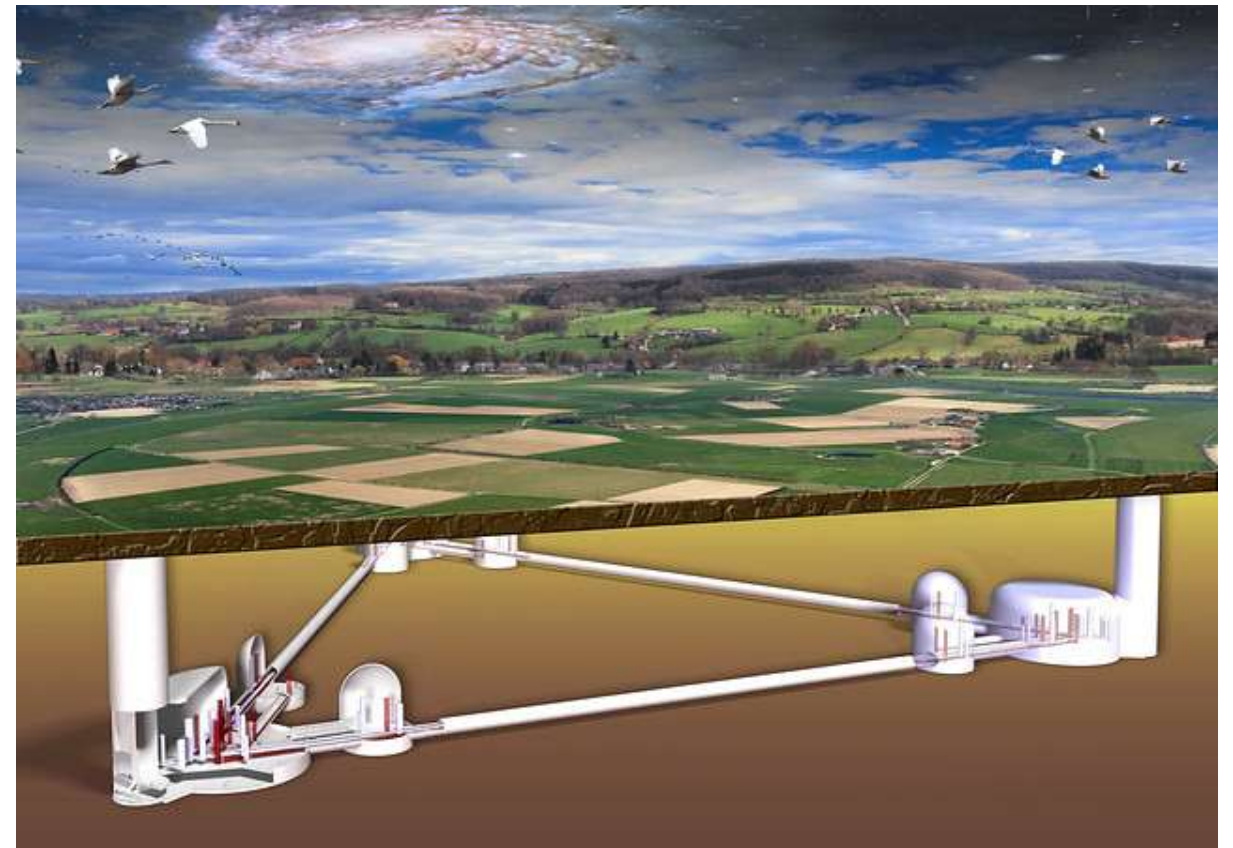

# The Modular Data Analysis Pipeline

*"As an evolving program is continually changed, its complexity, reflecting deteriorating structure, increases unless work is done to maintain or reduce it." Lehman (1980)*

# Modular approach to Signal Processing

- Division into modules
- Black-box vs. White box approach
- Normalized Systems Theory



## Data Version Transparency

Data structures can have multiple versions without affecting the processing functions that consume or produce them.



## Action Version Transparency

It should be possible to upgrade a processing function without affecting processing functions that call it.



## Separation of Concerns

A processing function should not address more than one concern and should thus not include more than one task.



## Separation of States

Tasks should clearly expose the state of their execution, so that errors can be correctly attributed to their causes.

*Fig 4. The four basic theorems of Normalized Systems Theory [2]*

# Modular Data Analysis pipeline

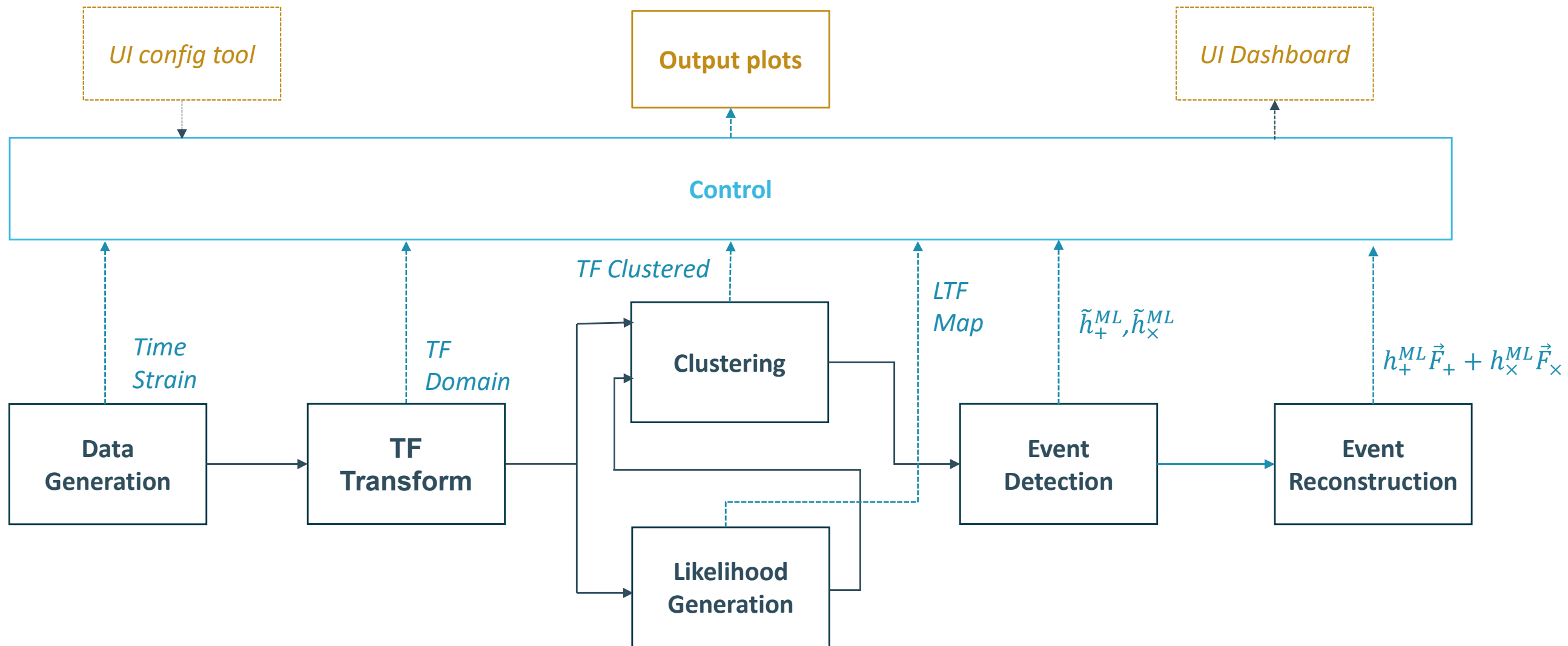

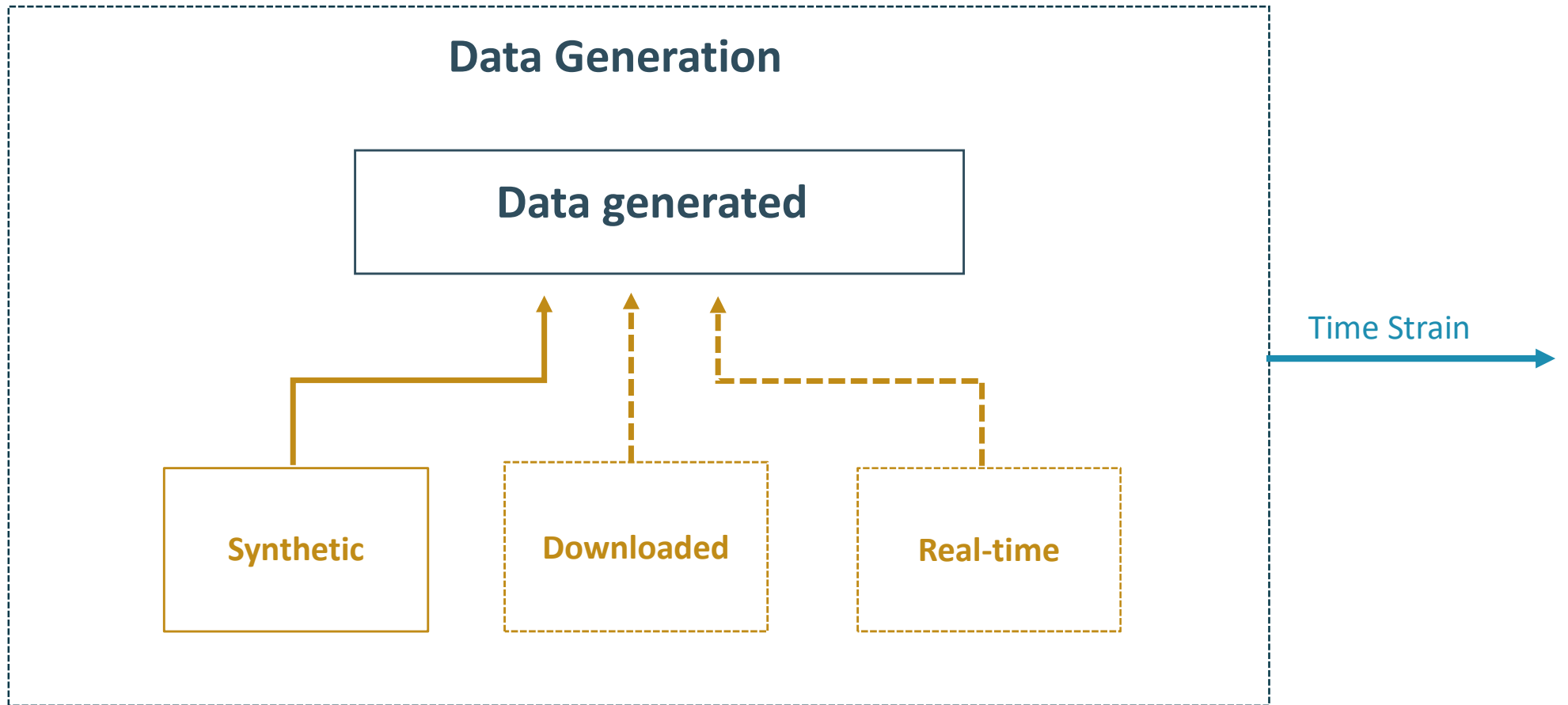

# Modular Data Analysis pipeline

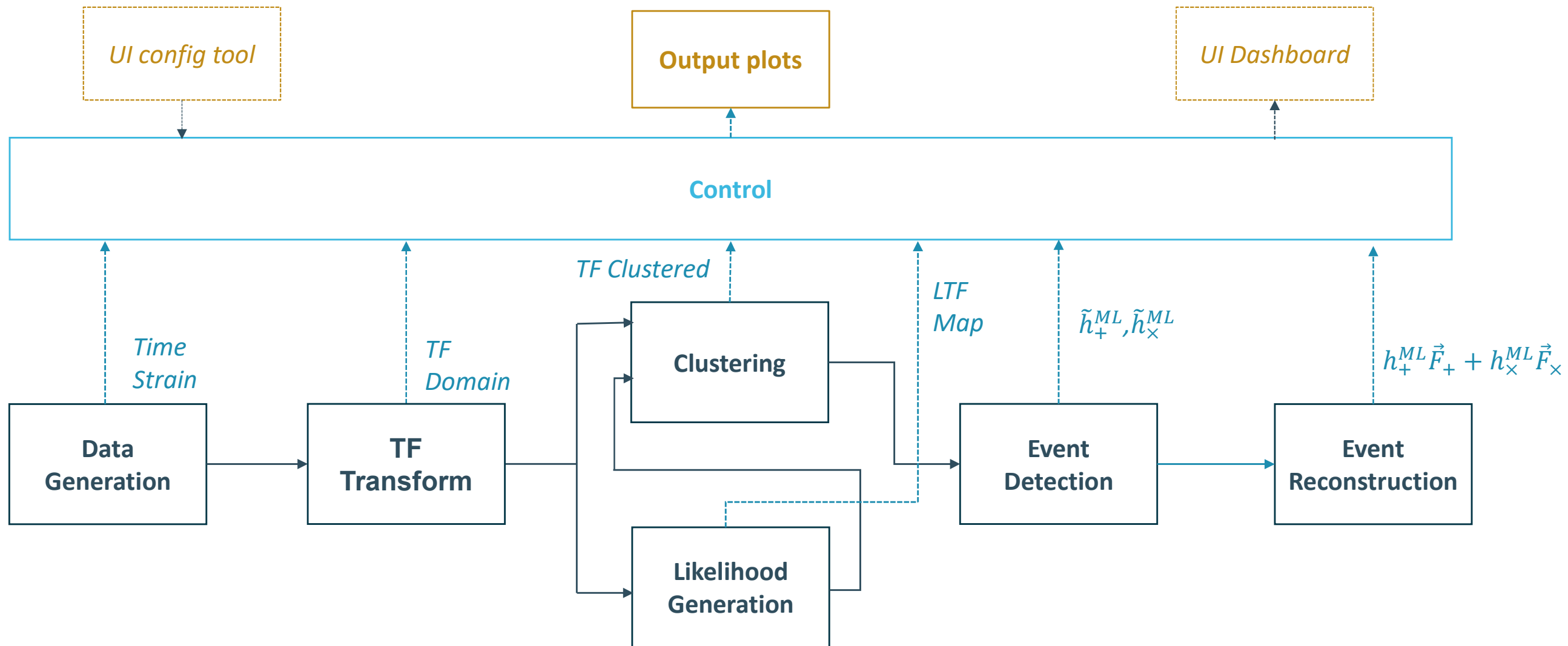

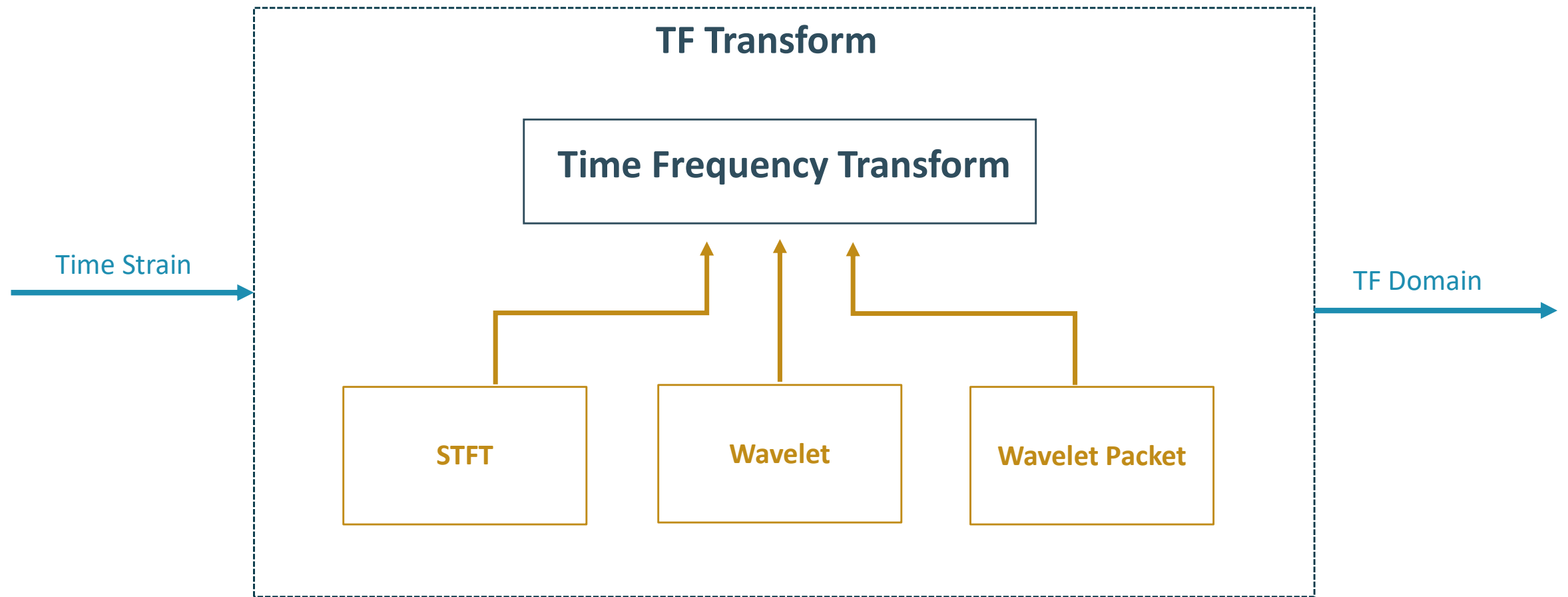

# Modular Data Analysis pipeline

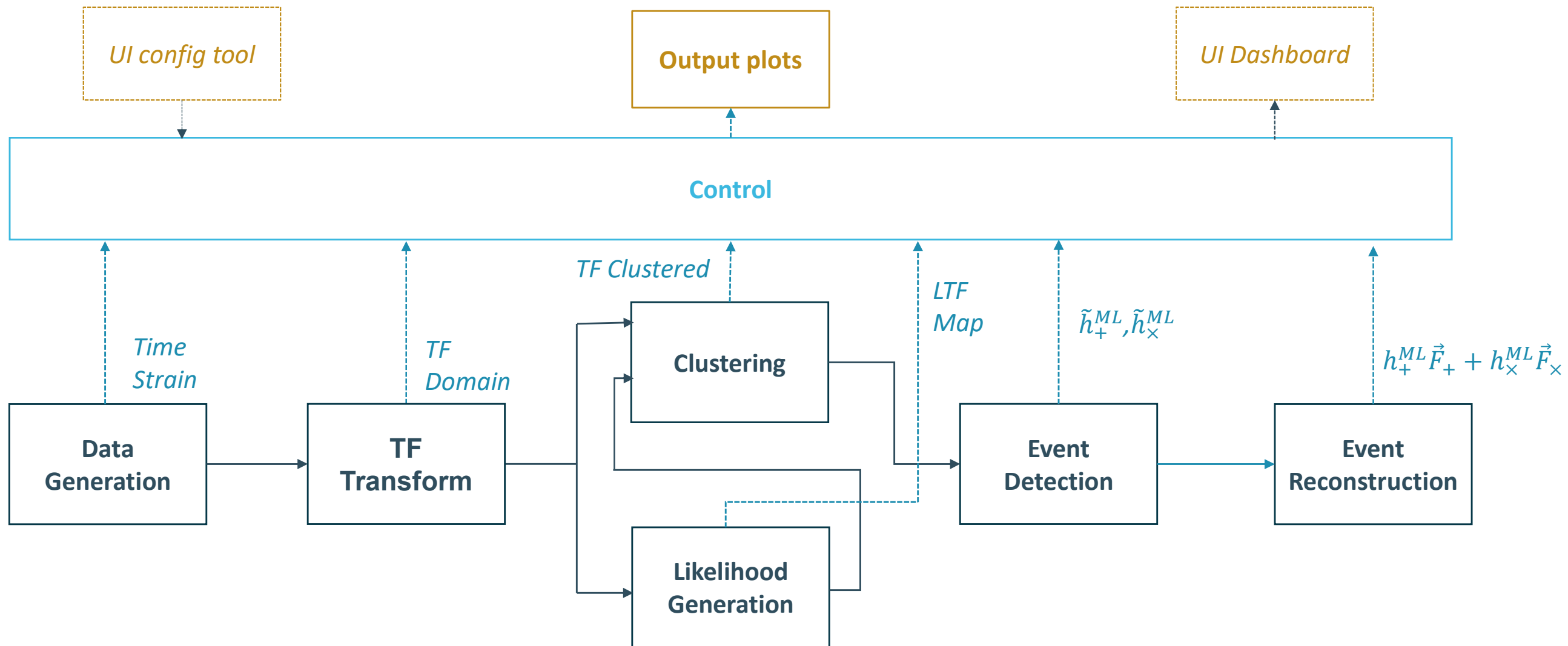

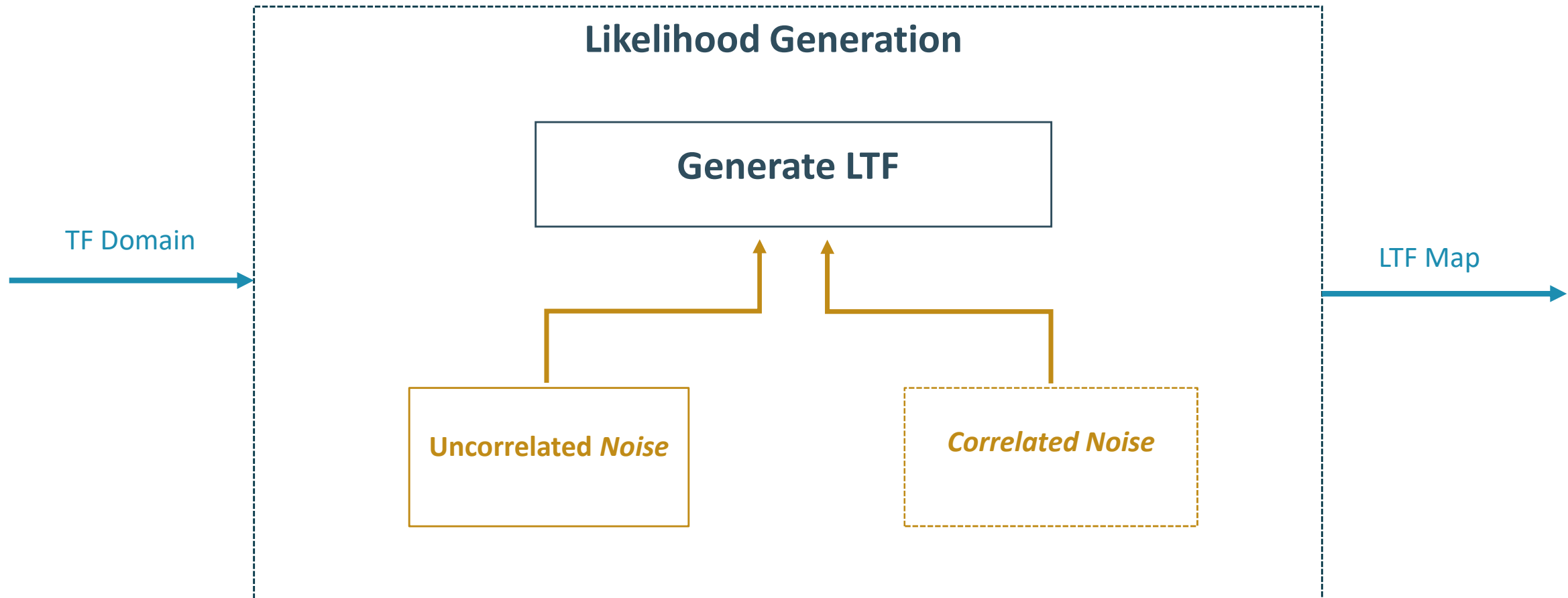

# Modular Data Analysis pipeline

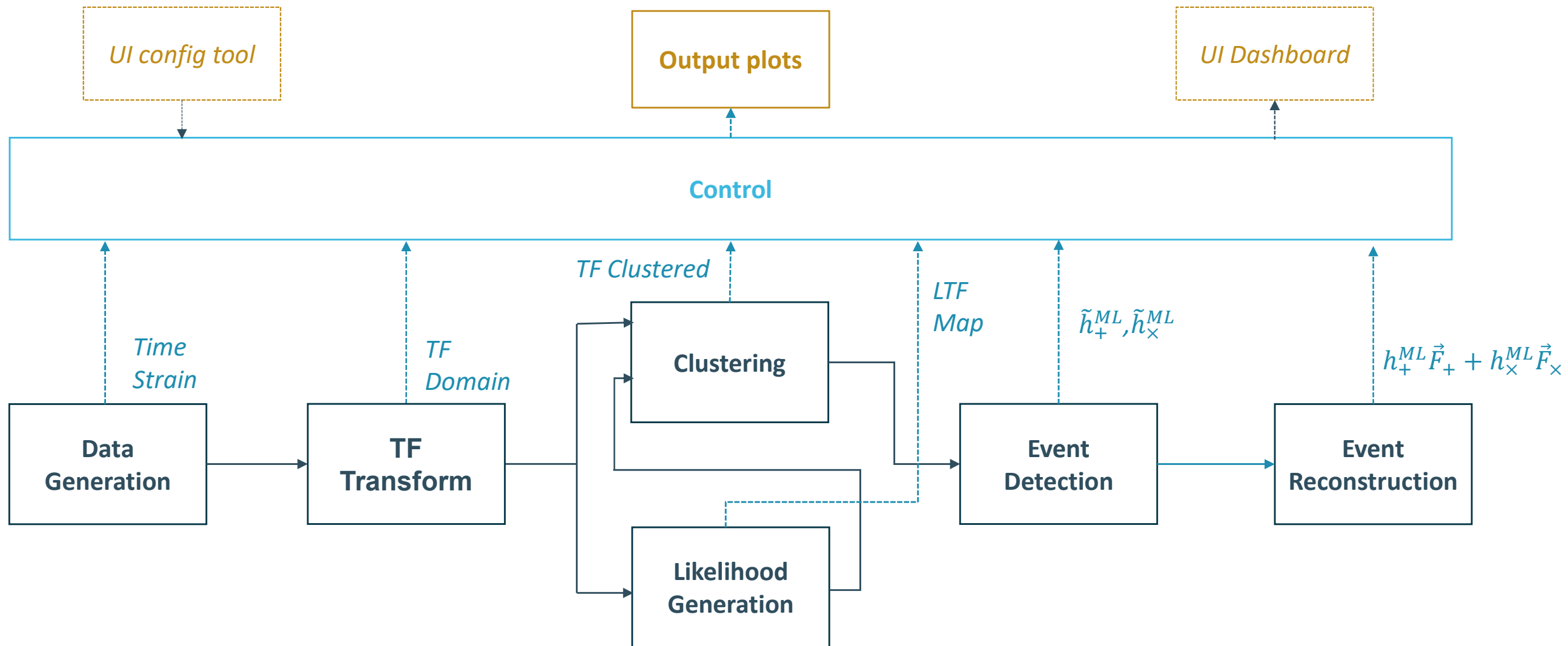

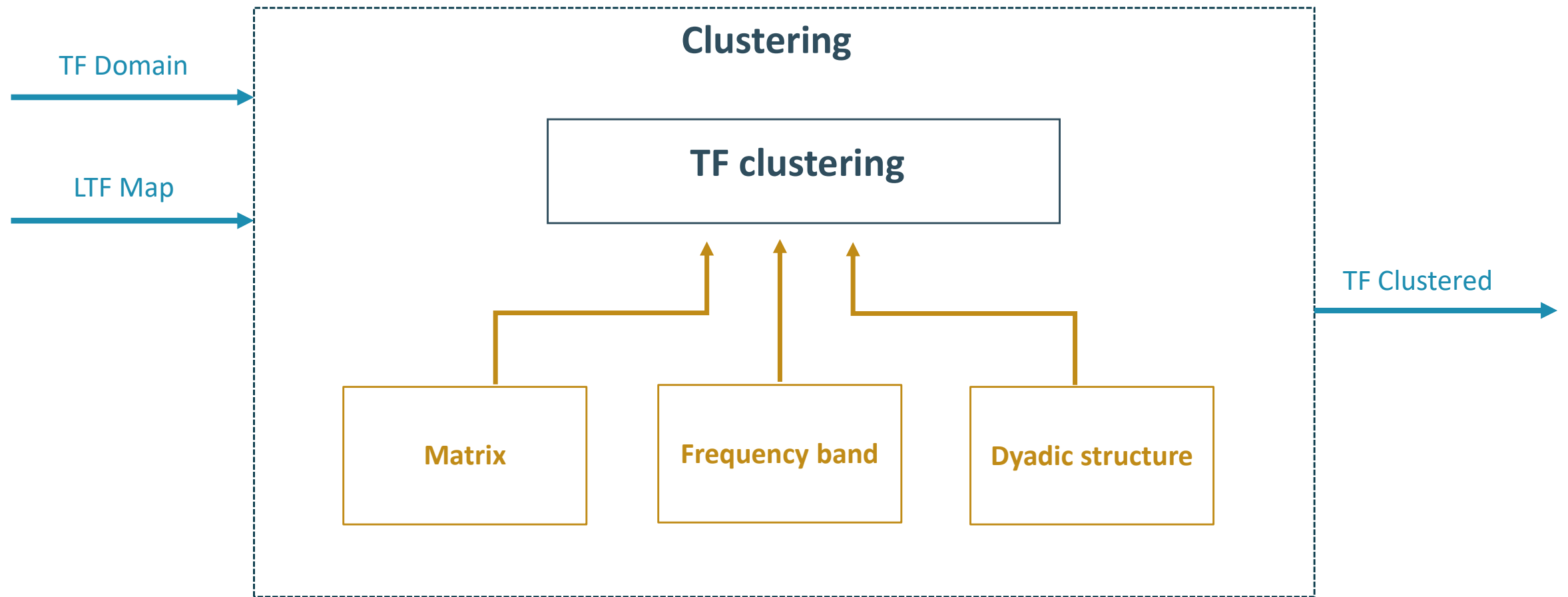

# Modular Data Analysis pipeline

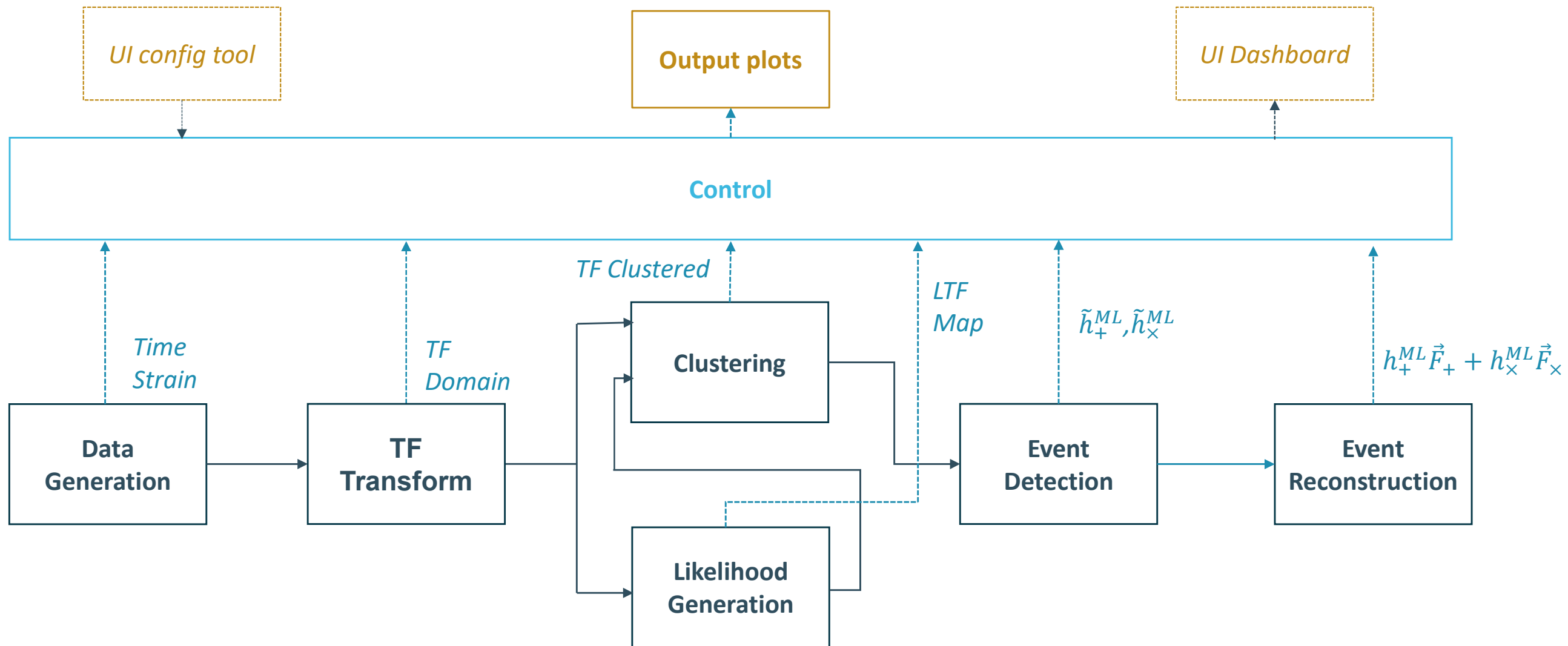

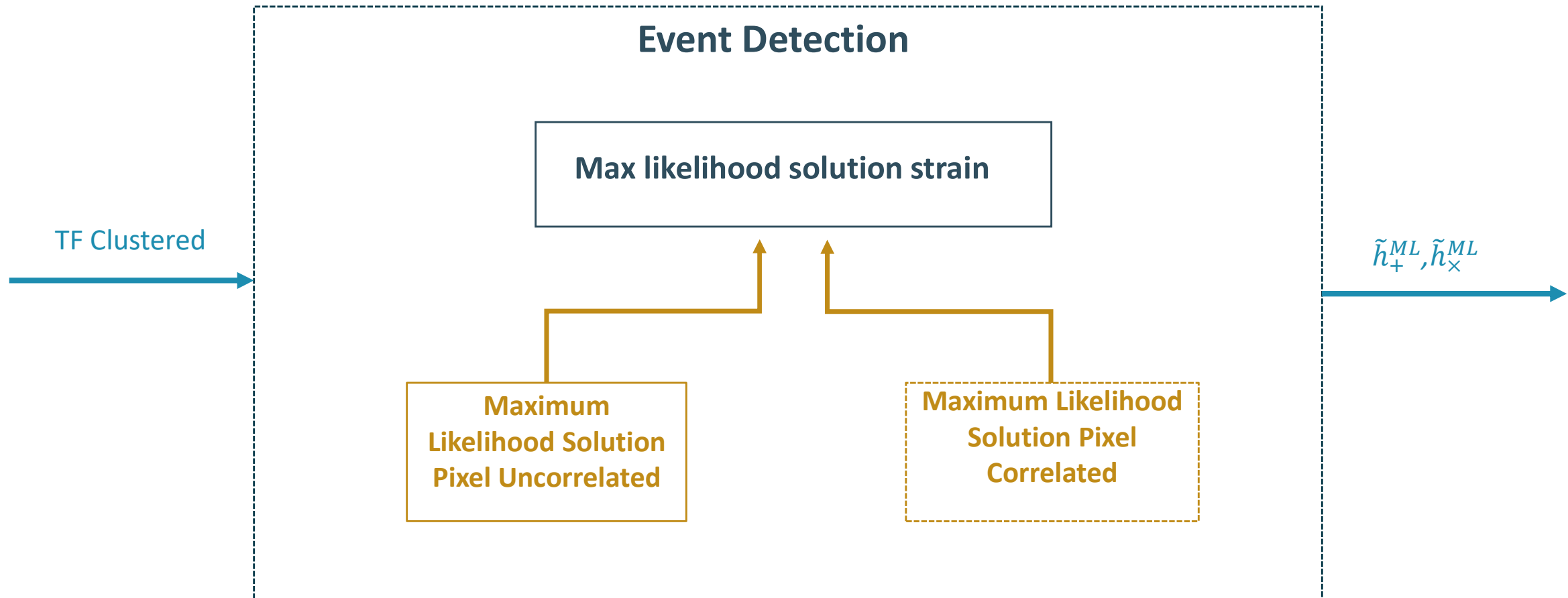

# Modular Data Analysis pipeline

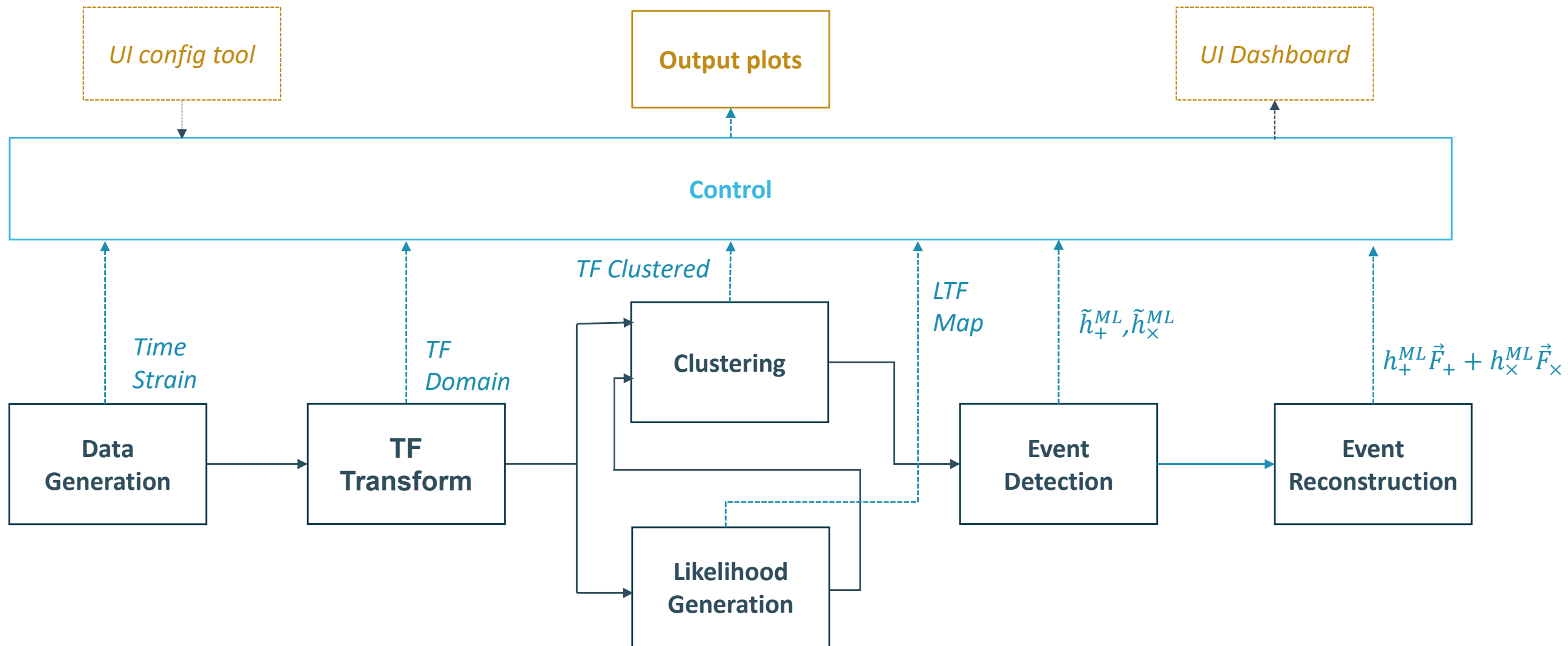

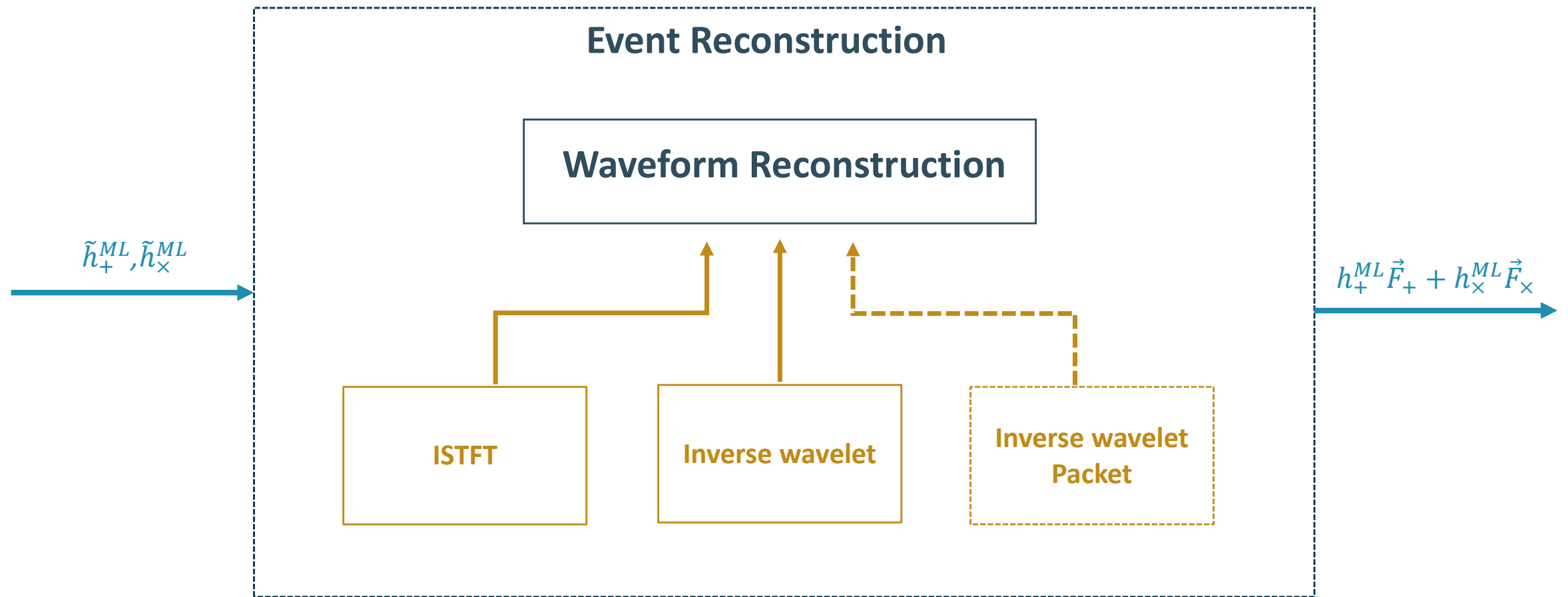

# Modular Data Analysis pipeline

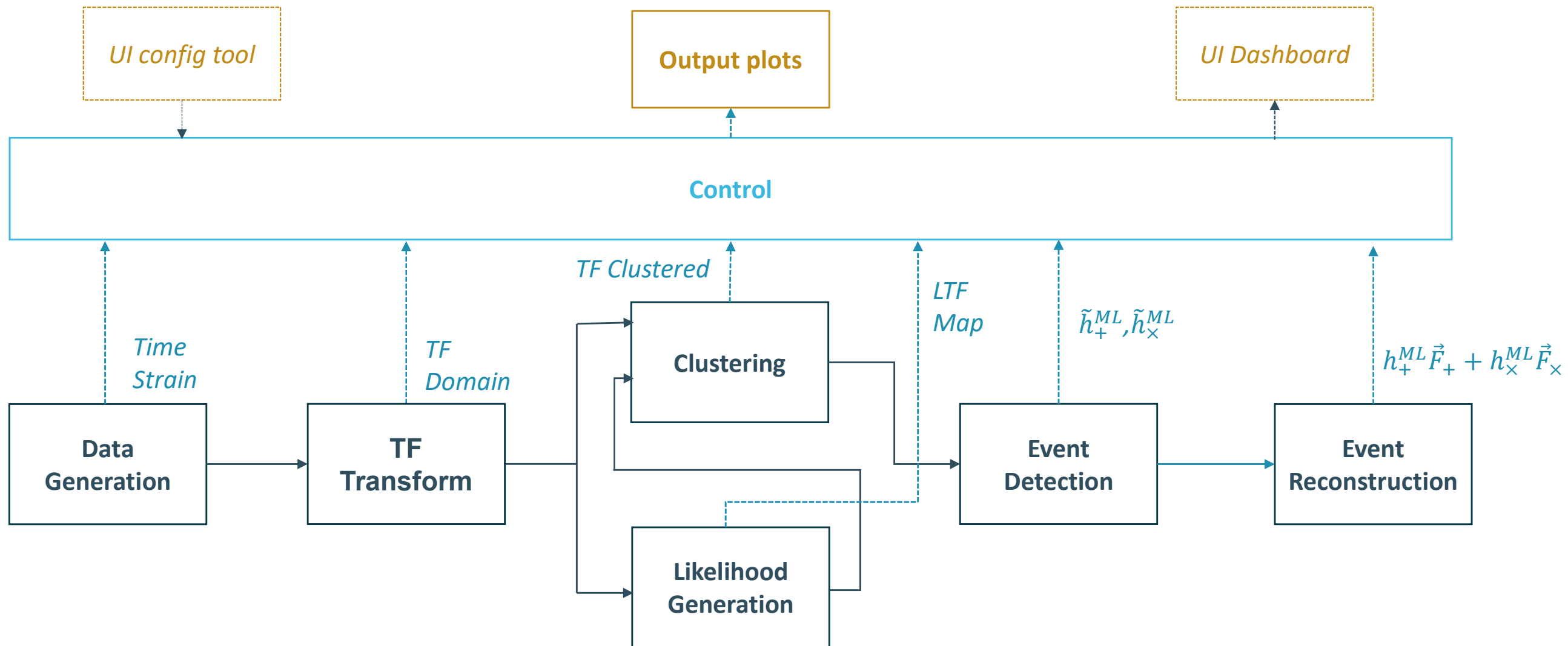

## Output plots

1. Time domain plot
2. TF plot: Uniform or Non-uniform
3. Wavelet transformation analysis plots
4. Likelihood analysis plots

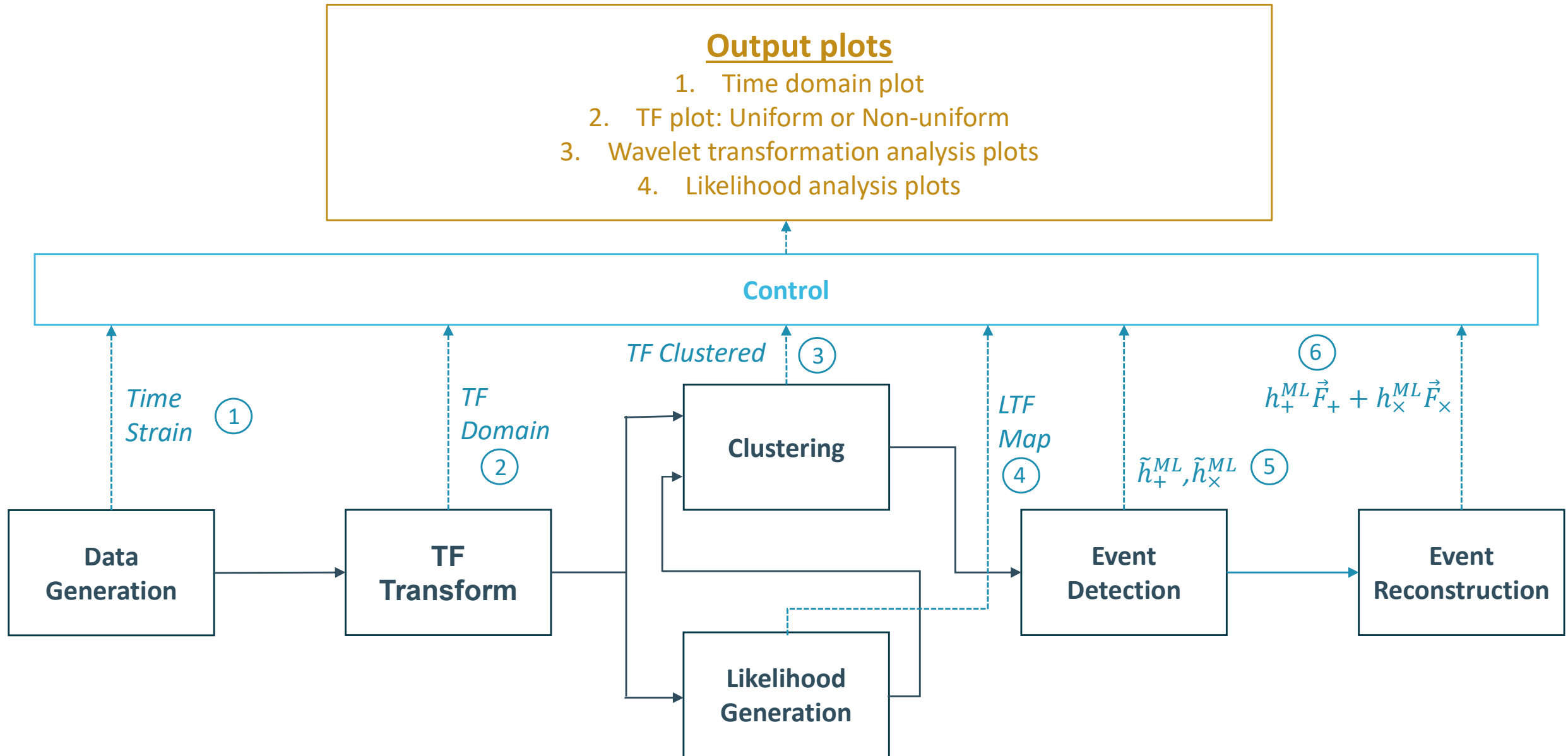

# Proof of concept : Wavelet Transformation Analysis



# The Time Frequency Transform

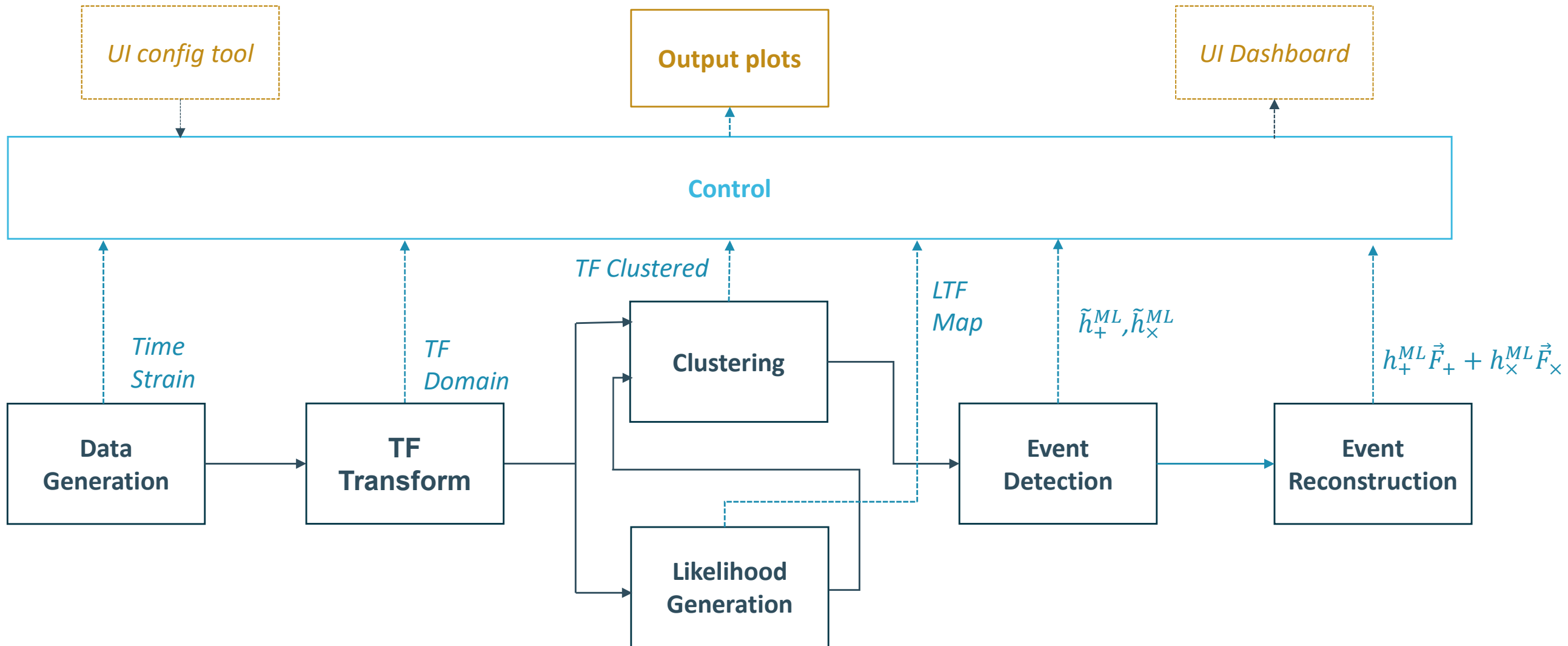

# Evaluations using the framework

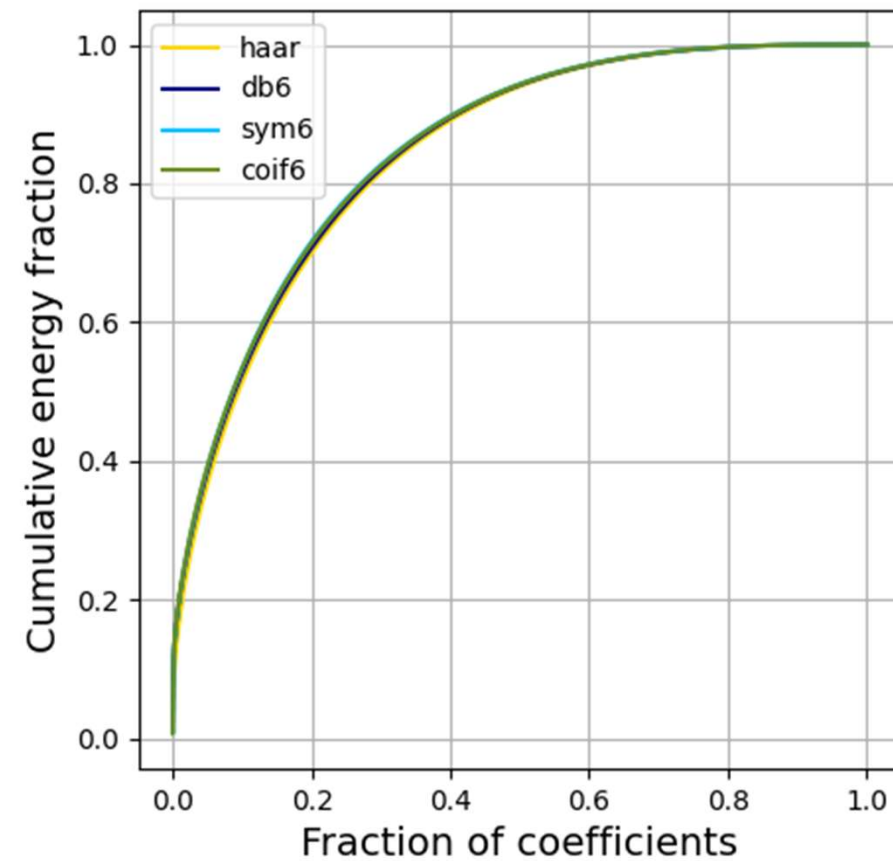
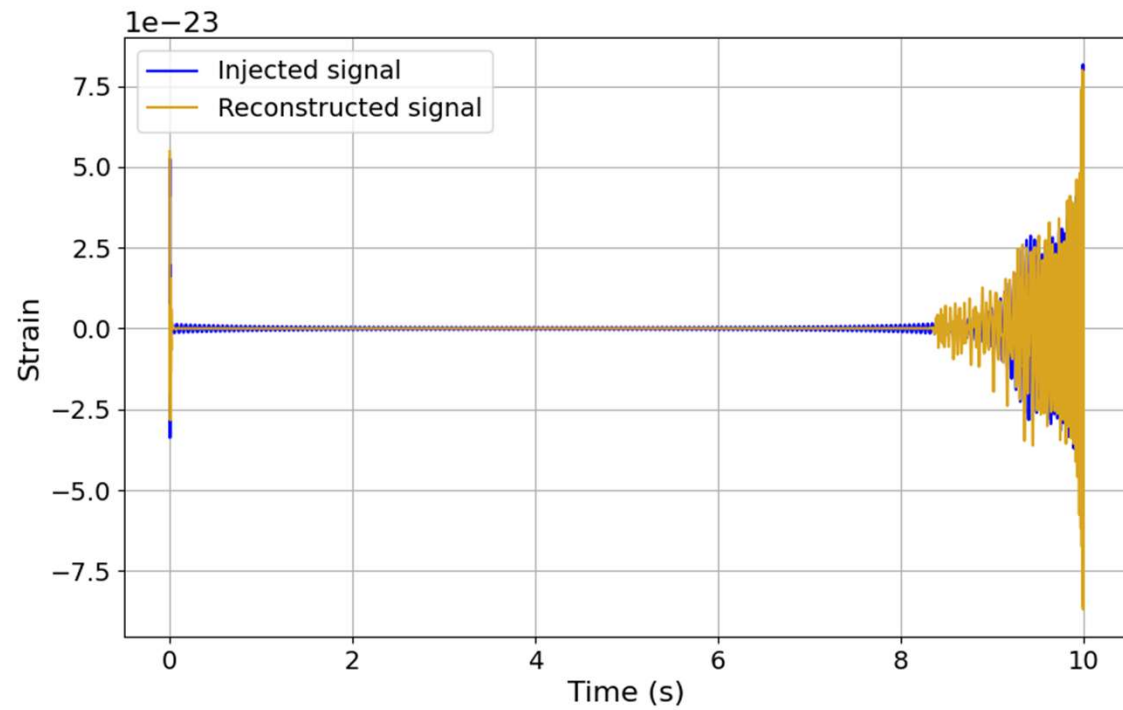

# Proof of concept: Likelihood Analysis



# Modular Data Analysis pipeline

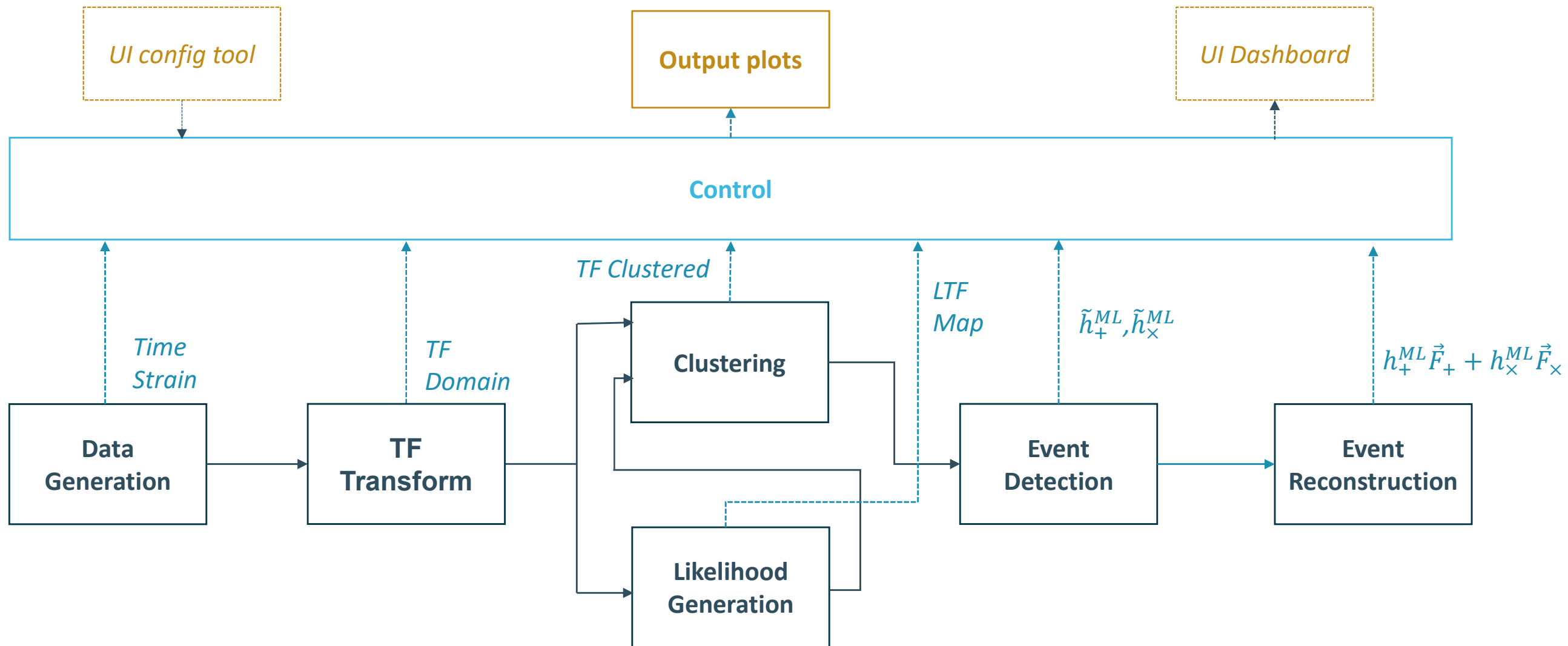

# Maximum Likelihood Solution

Pixel high noise power, [16Hz-32Hz]

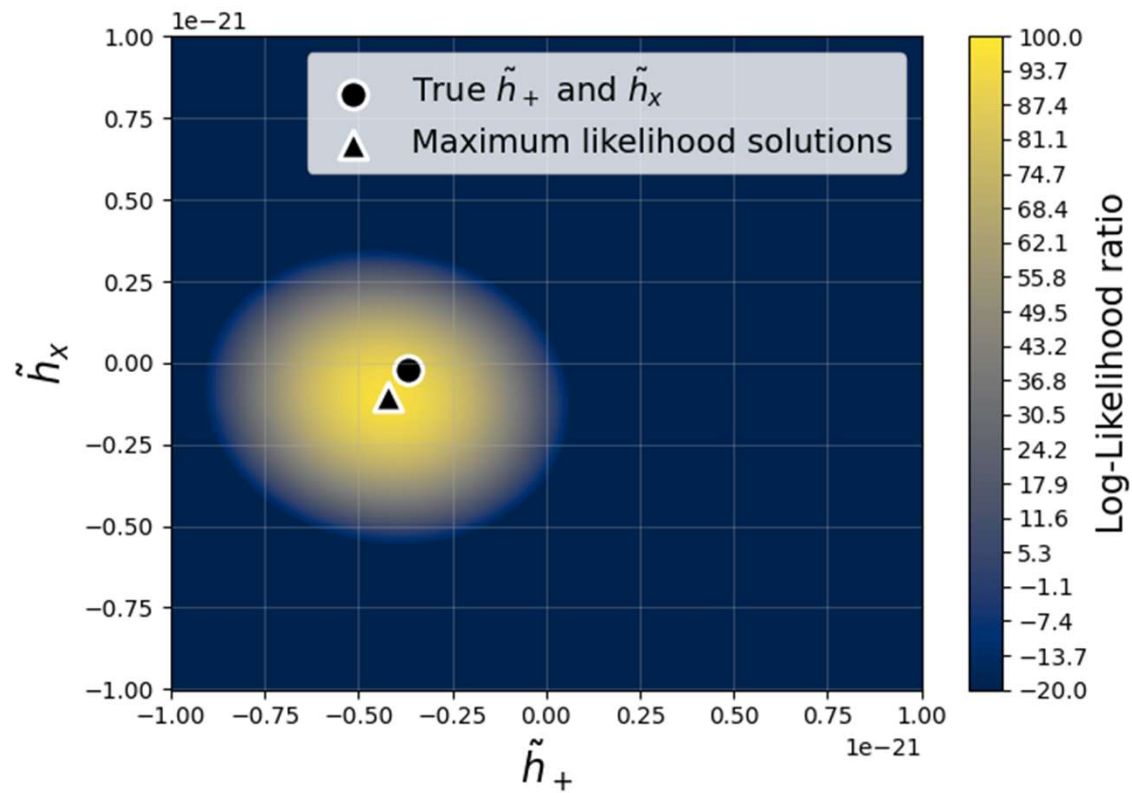

Noise power =  $1.2987 * 10^{-45}$

Pixel low noise power, [32Hz-64Hz]

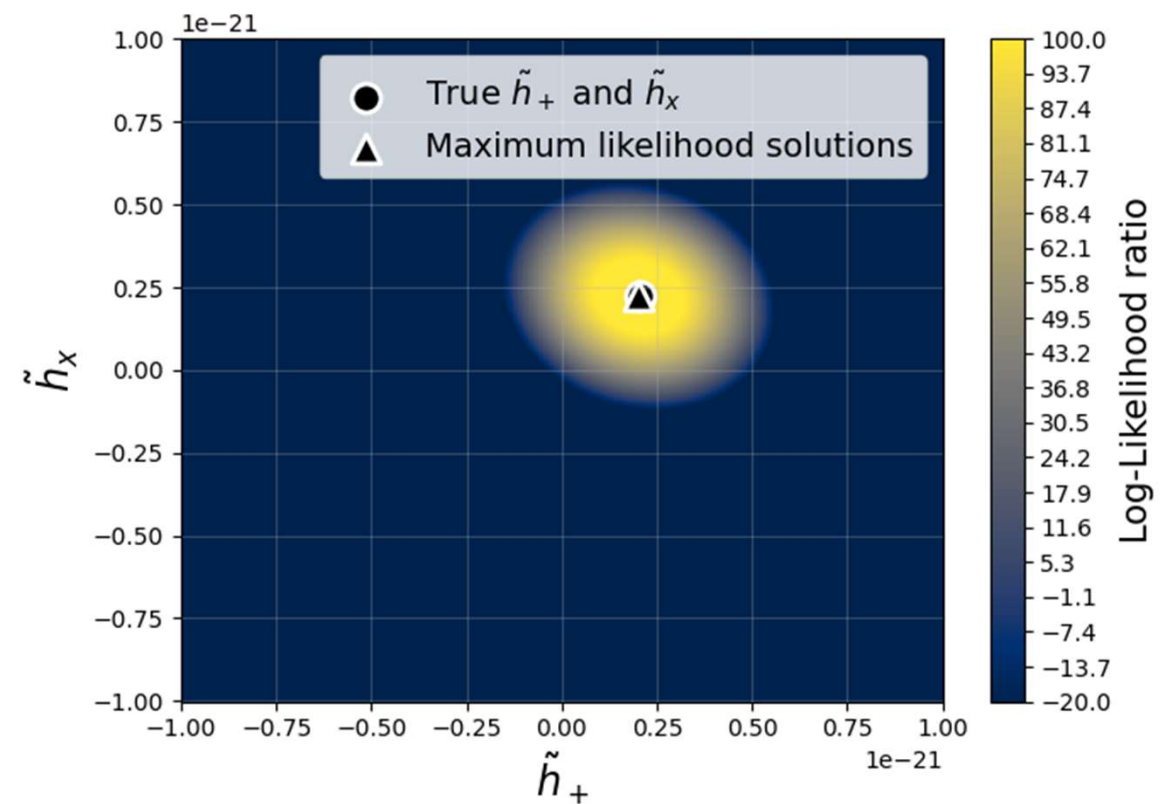

Noise power =  $0.0064 * 10^{-45}$

# Addressing the Problem of Noise Correlations

## Uncorrelated noise

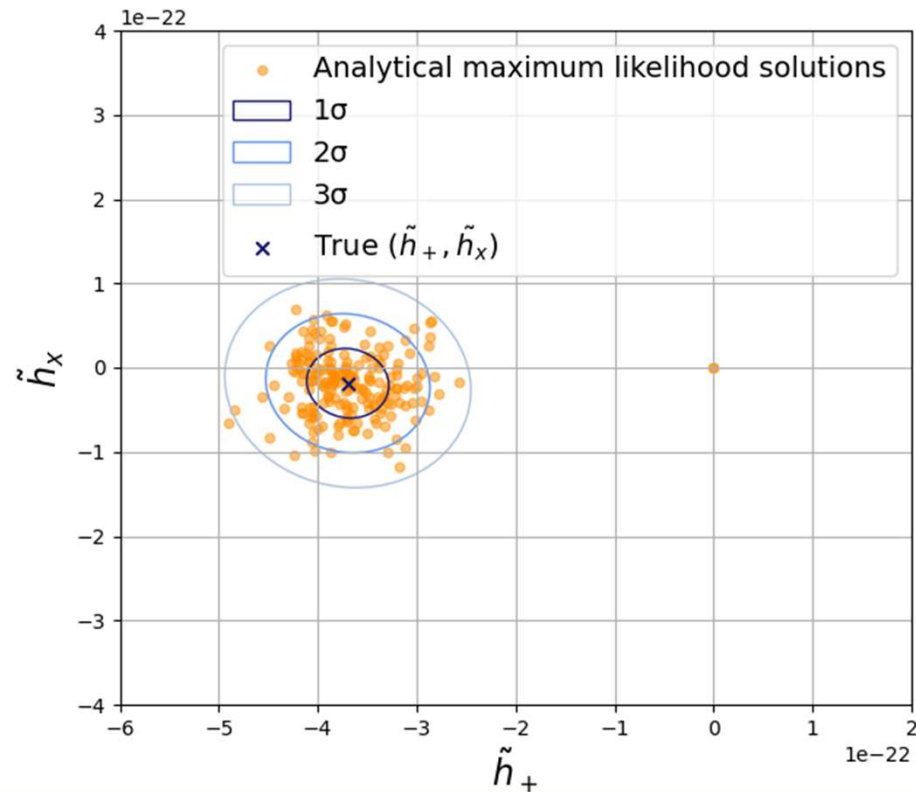

## Fully correlated noise interferometer 1&2

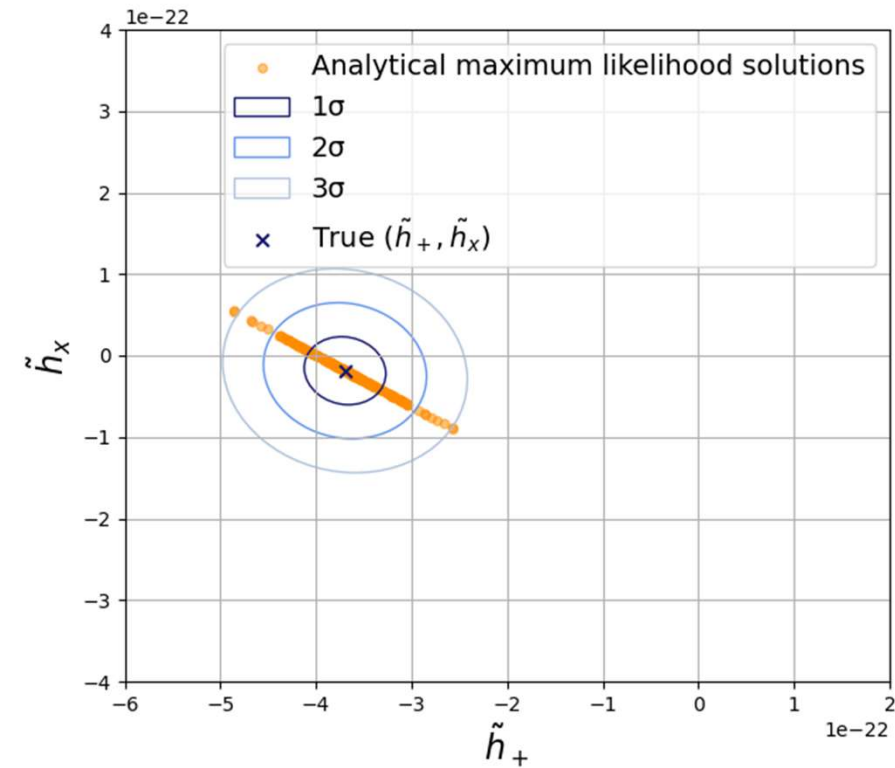

# Contribution of the project

**KU LEUVEN**



**LEUVEN GRAVITY INSTITUTE**



# Hearing Systems



# Hearing Systems Context

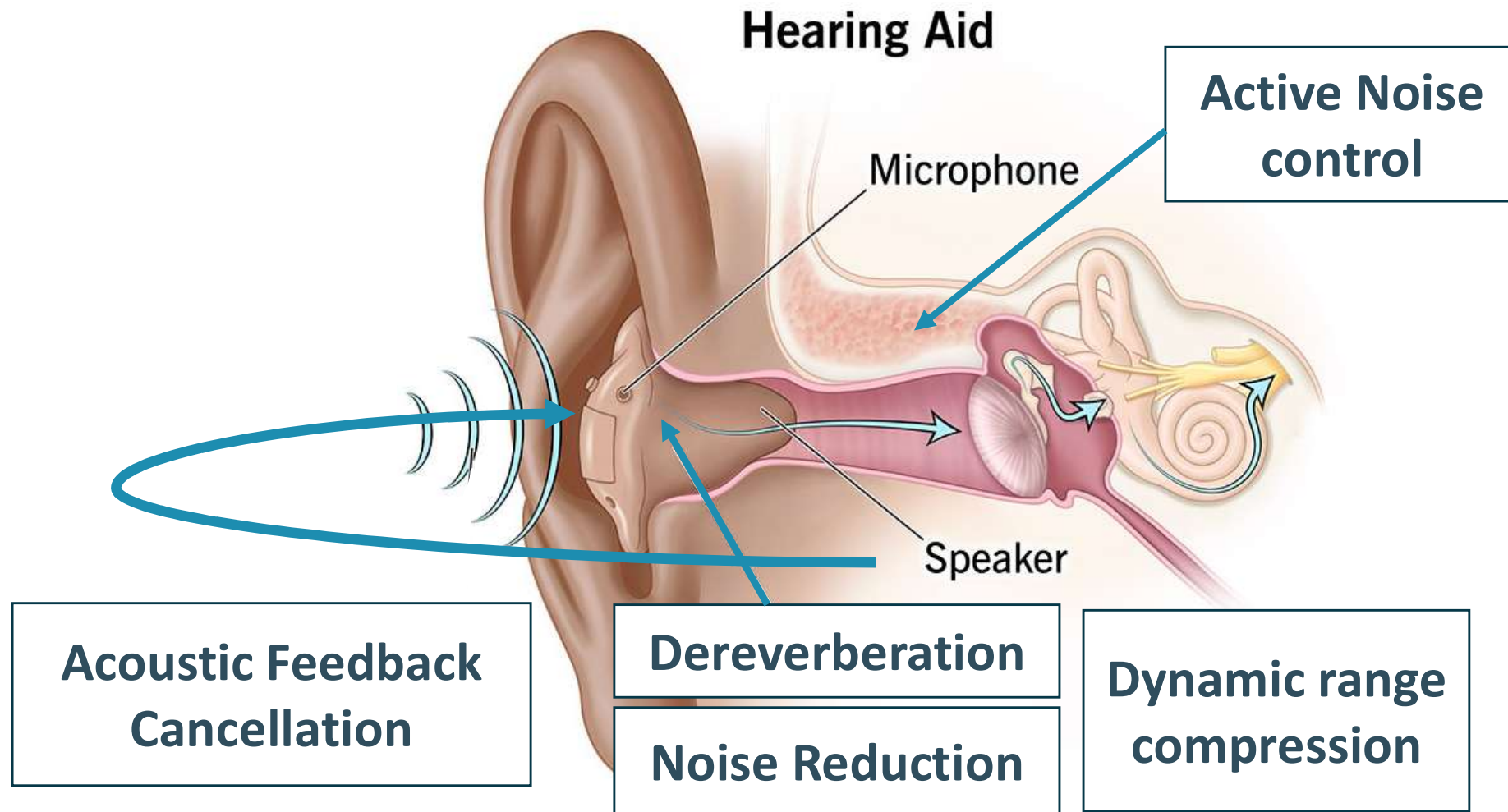

# Hearing System Platform



# Modular Data Analysis pipeline

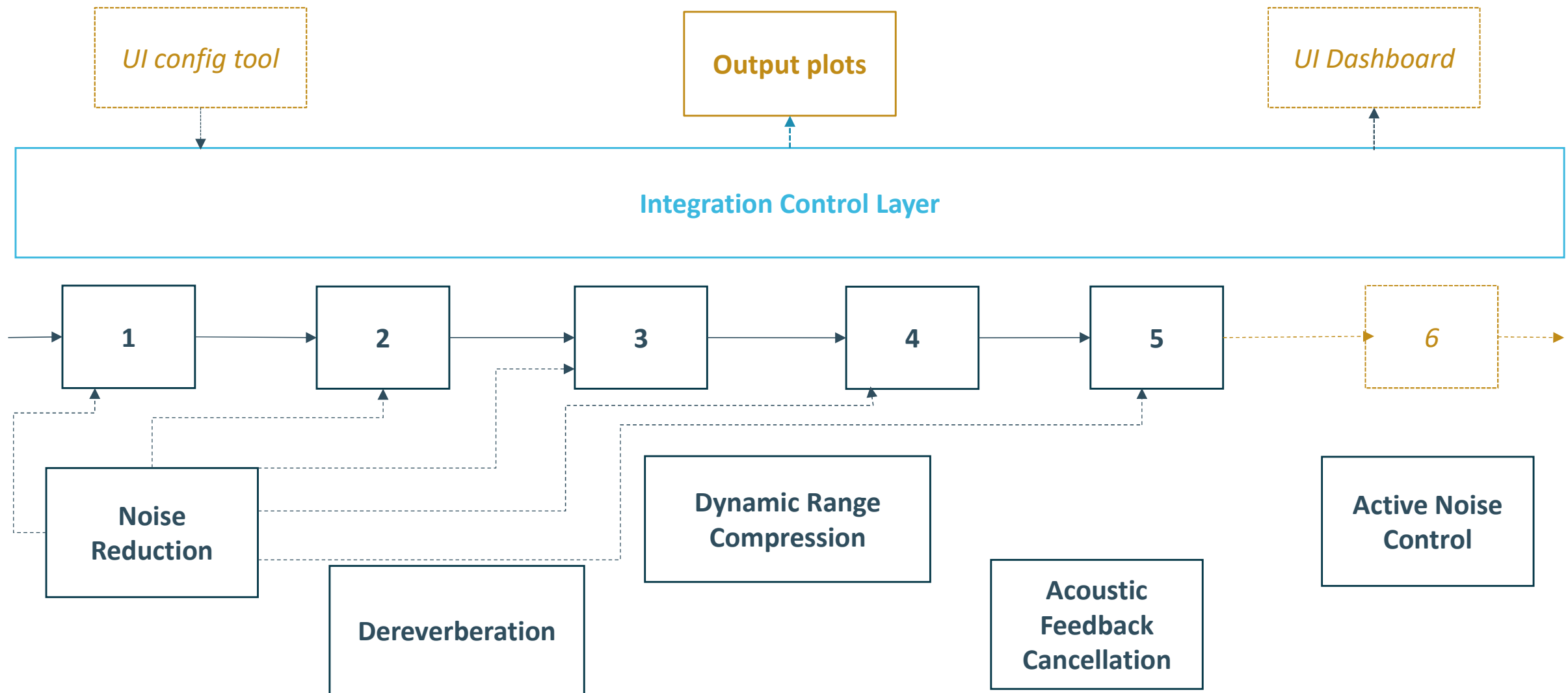

# Embedding in NSX software factory



# Design of a metamodel

➔ Model

➔ Meta Model

➔ Model

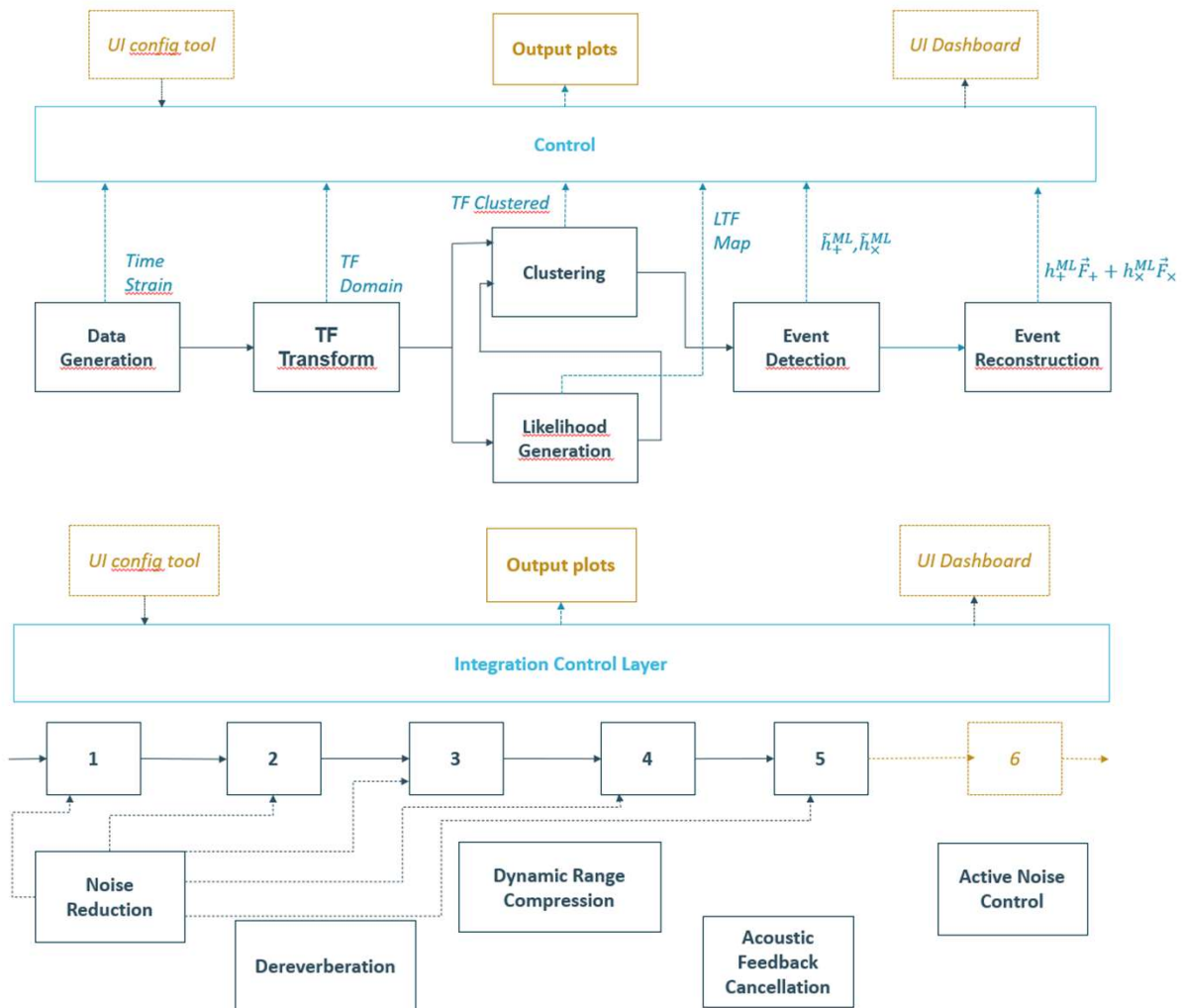

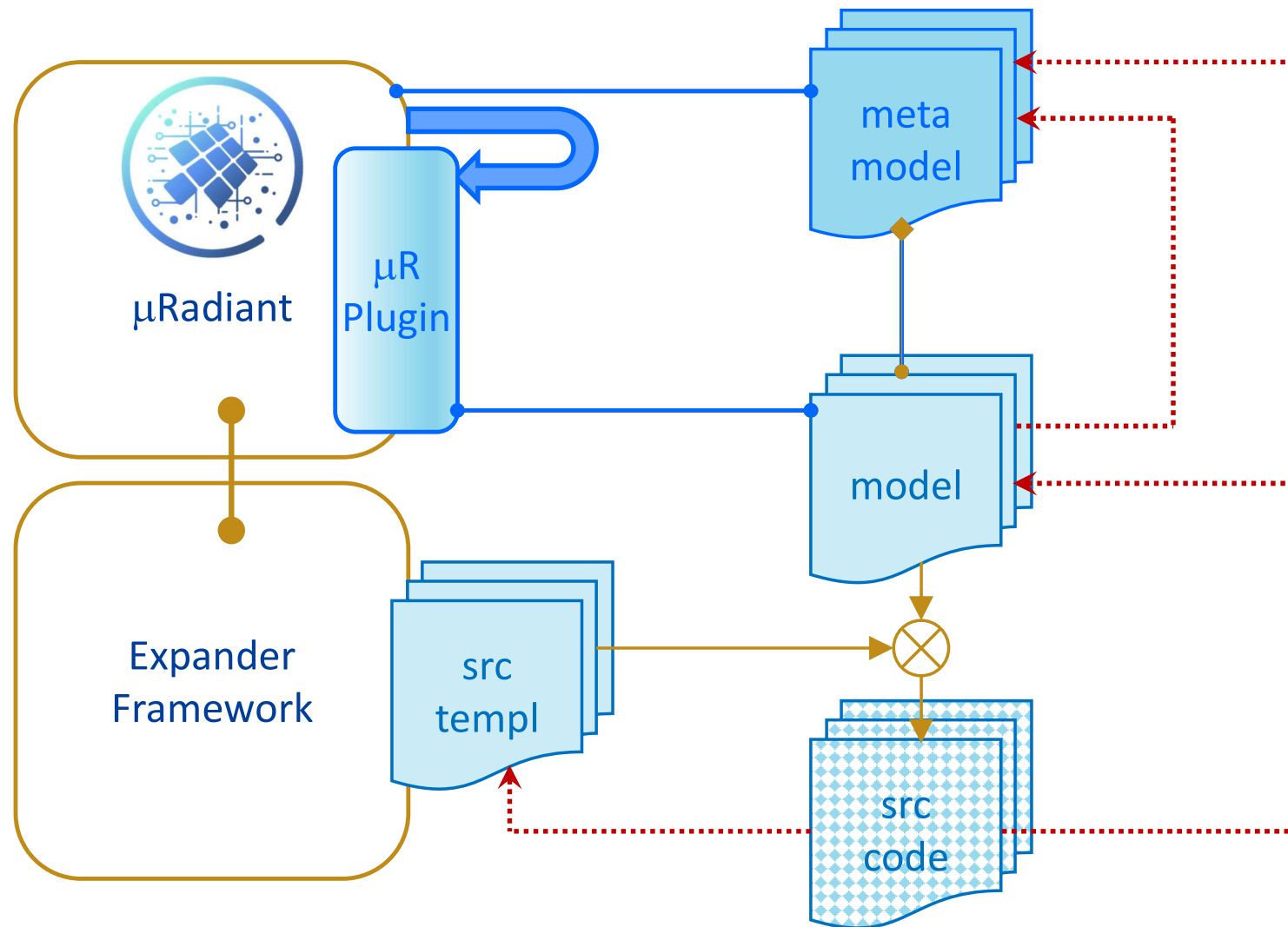

# Contribution of the project



# Application to other domains



# Digital Communication Systems

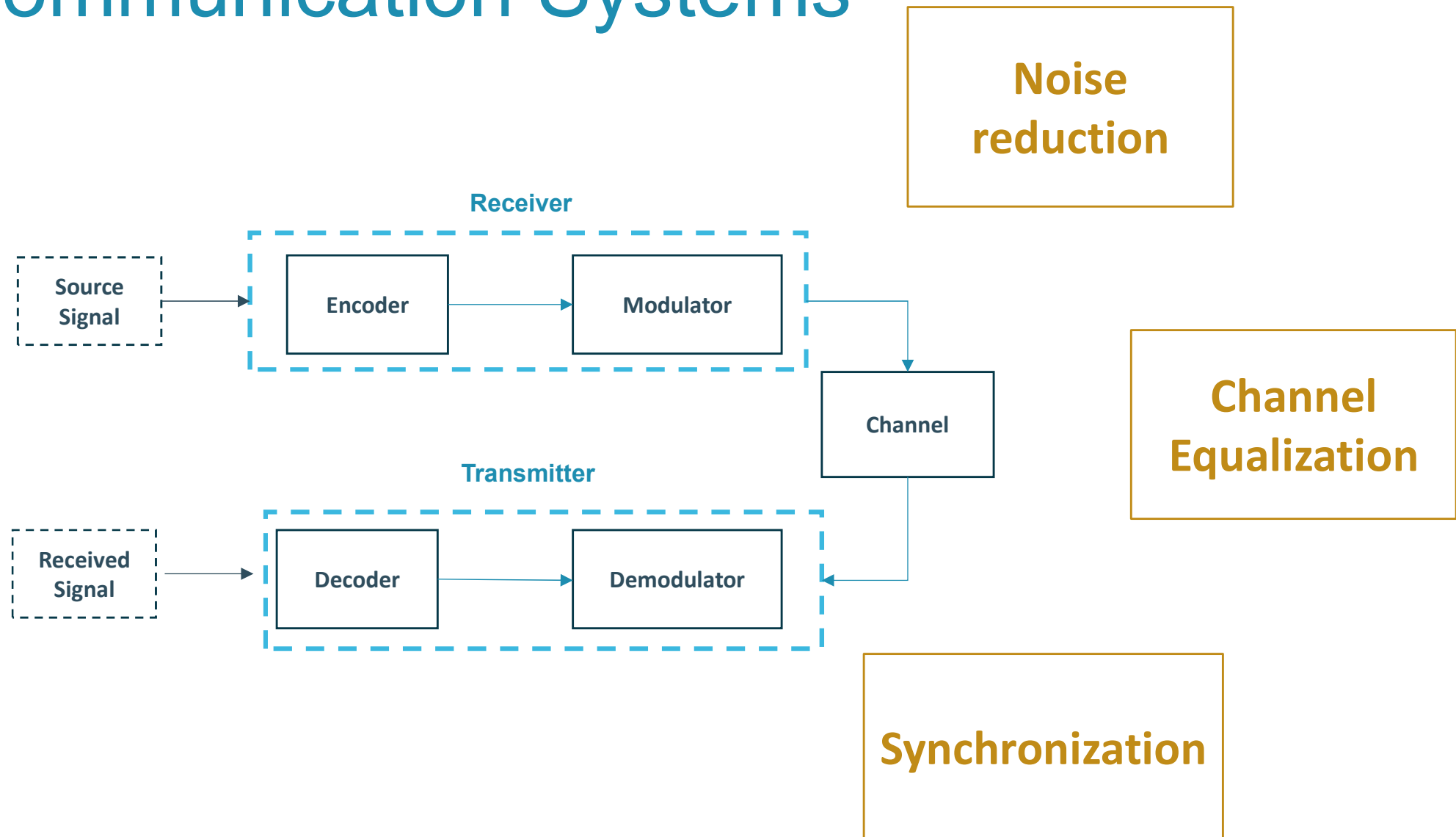

# Energy Sector

**Consumption  
Forecasting**

**Production  
Forecasting**

**Information  
System**



**Dynamic  
Pricing**

**Battery  
lifecycle  
estimation**

# Infusing AI?



# Integrating AI in Signal Processing applications

- Model based design vs Machine Learning design vs Hybrid design
- AI for optimization of the parameter space
- AI for glue code generation



**nsx**  
NORMALIZED SYSTEMS



**Digital Transformation**  
RESEARCH SOCIETY



**University  
of Antwerp**

**Thank you!**

[arwen.mannaert@esat.kuleuven.be](mailto:arwen.mannaert@esat.kuleuven.be)

[arwen.mannaert@nsx.normalizedsystems.org](mailto:arwen.mannaert@nsx.normalizedsystems.org)



**STADIUS**

Center for Dynamical Systems,  
Signal Processing and Data Analytics

**KU LEUVEN**



LEUVEN GRAVITY INSTITUTE

# References

- NSX, “NSX foundation,” 2024. [Online]. Available: <https://foundation.stars-end.net/>. [Accessed: Nov. 12, 2025]
- Mannaert Herwig, Verelst Jan, De Cock Koen, Faes Jeroen, **An integrated software manufacturing control system for a software factory with built-in rejuvenation**, Int. Journal Advances in Software, ISSN 1942-2628 - 17:1-2(2024), p. 90-99
- Mannaert Herwig , De Bruyn Peter, Verelst Jan, **On the Interconnection of Cross-Cutting Concerns within Hierarchical Architectures**, IEEE Transactions on Engineering Management - ISSN 1558-0040 - 69:6(2022), p. 3276-3291.
- Mannaert Herwig, McGroarty Chris, Gallant Scott, De Cock Koen, **Toward Scalable Collaborative Metaprogramming: A Case Study to Integrate Two Metaprogramming Environments**, Int. Journal on Advances in Software, ISSN 1942-2628 - 15:1-2(2022), p. 128-140
- De Bruyn Peter, Mannaert Herwig, Verelst Jan, Huysmans Philip, **Enabling normalized systems in practice : exploring a modeling approach**, Business & information systems engineering - ISSN 1867-0202 - 60:1(2018), p. 55-67.
- Mannaert Herwig, Verelst Jan, De Bruyn Peter, **Normalized systems theory : from foundations for evolvable software toward a general theory for evolvable design**, ISBN 978-90-77160-09-1 - Koppa, 2016, 507 p.
- Mannaert Herwig, Verelst Jan, Ven Kris, **Towards evolvable software architectures based on systems theoretic stability**, Software practice and experience - ISSN 0038-0644 - 42:1(2012), p. 89-116
- Mannaert Herwig , Verelst Jan, Ven Kris, **The transformation of requirements into software primitives : studying evolvability based on systems theoretic stability**, Science of computer programming - ISSN 0167-6423 - 76:12(2011), p. 1210-1222
- **Normalized Systems Foundation Lectures** : <https://www.youtube.com/c/normalizedsystems>
- **Normalized Systems Documentation and Tooling** : <https://foundation.stars-end.net>